

PRODUCT NO SEE SHEET 2

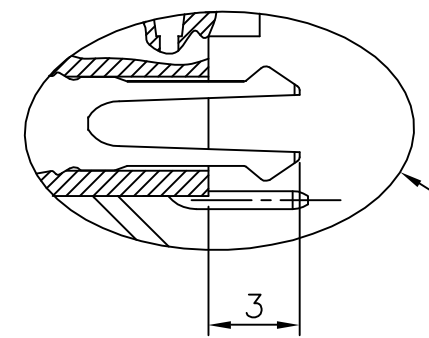

P.C. MOUNTING HOLE PATTERN

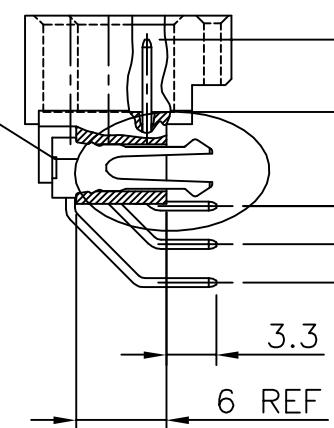
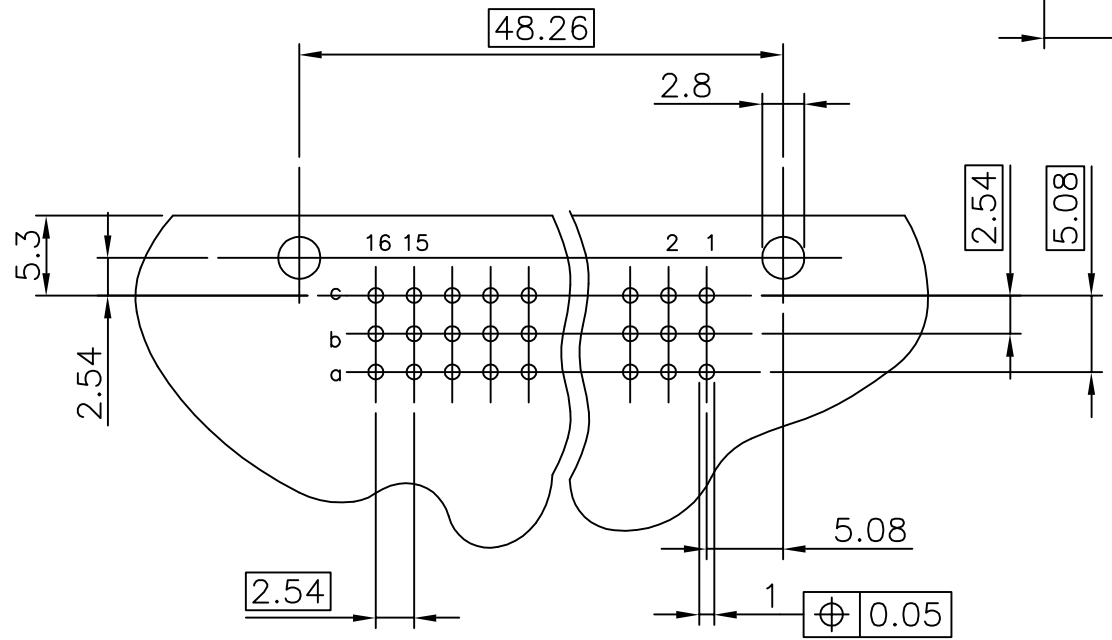

DIM "A" +0.2
0
SEE NOTE 2

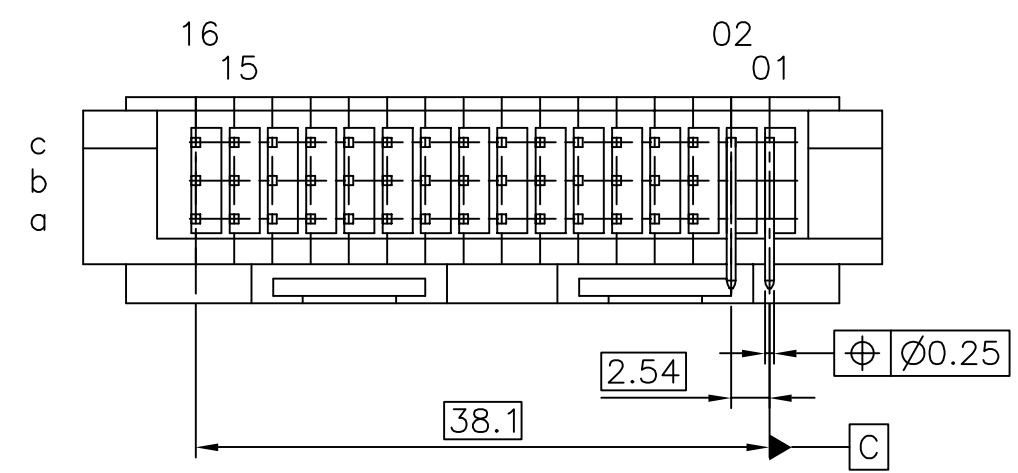
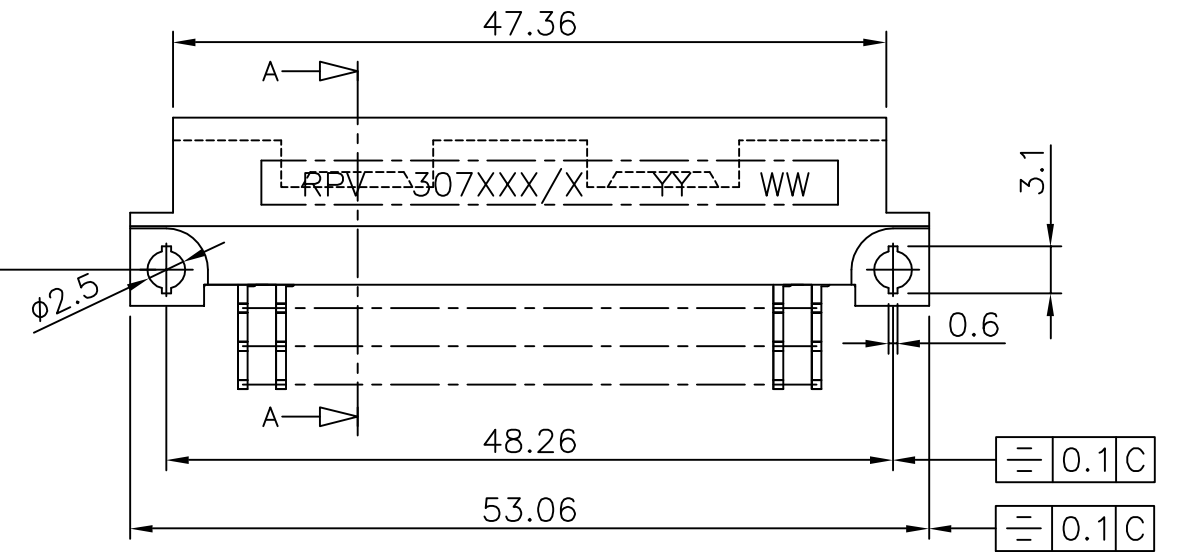
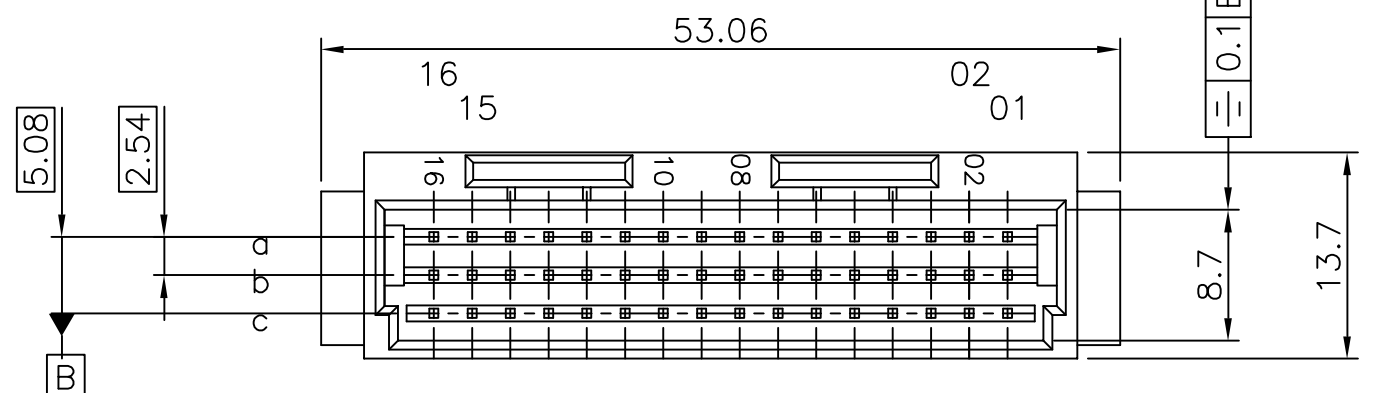

NOTES:
 1. TIN LEAD PLATING HAS BEEN REPLACED BY PURE MATT TIN PLATING ON THE CONNECTOR TERMINATIONS. NO CHANGE IN THE HOUSING MATERIAL.
 2. CUSTOMER NEEDS TO DECIDE & STANDARDIZE ON SUITABLE PROTECTION DEVICES TO PROTECT THE CONNECTOR HOUSINGS FROM THE HIGHER TEMPERATURE REQUIREMENTS OF LEAD FREE WAVE SOLDERING. REGULAR USE OF THESE CONNECTORS TO BE STARTED ONLY AFTER THIS REQUIREMENT HAS BEEN MET.
 3. RoHS COMPLIANT LOGO WILL BE PROVIDED ON LABELS AS PER THE GLOBAL PACKAGING SPECIFICATION GS-14-920.

mat'l. code SEE NOTES, SHEET 2				surface ISO 1302 ✓ ISO 406 ISO 1101		tolerance tolerances unless otherwise specified		projection mm		product family BACKPANEL	
ltr				ecn no		dr		date		title DIN HEADER ASSEMBLY	
A				F030287		DLE		2003-10-10		sheet 1 of 2	
B				I06-0082		MINI		2006-06-01		size A3	
C				I07-0079		KR		2007-06-26		type Product Customer Drawing	
sheet index				revision		C		C		dwg no 72937	
				sheet		1		2		scale 1:1	
										FCJ	

PRODUCT NO	CUSTOMER PART NUMBER	PIN "X" PLACED IN POSITION														CLIPS			
		ROW	16	15	14	13	12	11	10	9	8	7	6	5	4		3	2	1
72937-002	RPV 307 202/2	a	X	X	X	X	X	X	X	X	X	X	X	X	X	X	X	X	NO
		b																	
		c	X	X	X	X	X	X	X	X	X	X	X	X	X	X	X	X	
72937-003	RPV 307 202/3	a	X	X	X	X	X	X	X	X	X	X	X	X	X	X	X	X	NO
		b	X	X	X	X	X	X	X	X	X	X	X	X	X	X	X	X	
		c	X	X	X	X	X	X	X	X	X	X	X	X	X	X	X	X	
72937-015		a	X	X	X	X	X	X	X	X	X	X	X	X	X	X	X	X	YES
		b																	
		c	X	X	X	X	X	X	X	X	X	X	X	X	X	X	X	X	



NOTES:

- 1 - MATERIAL BODY : POLYCARBONATE PLASTIC
MATERIAL PIN : PHOSPHOR BRONZE
- 2 - NORMAL CONTACT "X" AND "Δ" DIM A= 4.8
FMLB CONTACT "O" (EARTH PIN) DIM A= 5.4
- 3 - PRINTING CONSISTS OF RPV 307 XXX/X YY WW
 CUSTOMER P/N ←
 YEAR ←
 WEEK ←
- 4 - CLIPS FOR PCB THICKNESS 1.6mm.
- 5 - CONTACT ZONE PLATING : Au OVER Ni
 TERMINAL ZONE PLATING : Sn (PURE MATT) OVER Ni
 CLIP PLATING : Sn (PURE MATT) OVER Ni

mat'l. code SEE NOTES				surface ISO 1302 ✓		tolerance ISO 406 ISO 1101		projection 		product family BACKPANEL			
ltr				ecn no		dr		date		tolerances unless otherwise specified		title DIN HEADER ASSEMBLY	
A				F030287		DLE		2003-10-10		angles		linear	
B				106-0082		MINI		2006-06-01		mm		scale N/A	
C				107-0079		KR		2007-06-26		FCI		dwg no 72937	
												sheet 2 of 2 A3	
												type Product Customer Drawing	
sheet index		revision sheet											